



### 材質 | Material

SCG 系列-鋁合金 Aluminum alloy  
SCGS 系列-不銹鋼 Stainless steel

### 表面處理 | Surface Treatment

陽極處理 Anodizing standard white

### 特性 | Features

- |   |   |
|---|---|
| <ol style="list-style-type: none"> <li>1. 一體成型</li> <li>2. 超高剛性</li> <li>3. 高扭力</li> <li>4. 低慣性</li> <li>5. 固定方式：止付螺絲固定式</li> </ol> | <ul style="list-style-type: none"> <li>• One-body shape</li> <li>• Super high rigid</li> <li>• High torque</li> <li>• Low inertia</li> <li>• Fixed mode : Set screw type</li> </ul> |
|---|---|

### 型號表示 | Product NO

**SCG-20 -  $\phi 6 \times \phi 6$**

型號 / Type      孔徑 / Inside dia

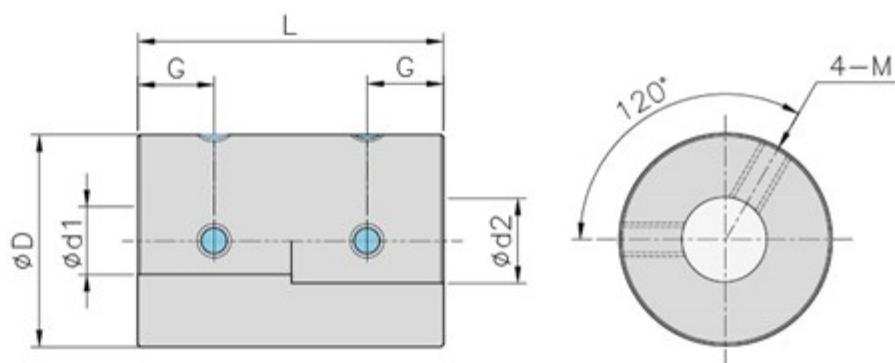

### 尺寸 | Dimension

單位 / Unit:mm

Catalog Number 型號	D	L	G	M	d1xd2 標準孔徑 (H7)		Mass** 重量 (g)
					Min	Max	
SCG-16	16	24	6	M3	5	8	11
SCG-20	20	30	7	M4	6	10	20
SCG-25	25	36	9	M4	6	12	45
SCG-32	32	41	10	M5	8	16	89
SCGS-16	16	24	6	M3	5	8	31
SCGS-20	20	30	7	M4	6	10	69
SCGS-25	25	36	9	M4	6	12	133
SCGS-32	32	41	10	M5	8	16	253

### 性能 | Specifications

單位 / Unit:mm

Catalog Number 型號	Rated Torque 一般扭力 (N.m)	Max. Torque 最大扭力 (N.m)	Max Rotational Frequency 最高回轉速 (Rpm/min)	Moment* of Inertia 慣性 (Kg · m <sup>2</sup> )
SCG-16	0.3	0.6	24000	4.4x10 <sup>-7</sup>
SCG-20	0.5	1.0	19000	1.3x10 <sup>-6</sup>
SCG-25	1.0	2.0	15000	3.9x10 <sup>-6</sup>
SCG-32	2.0	4.0	12000	1.2x10 <sup>-5</sup>
SCGS-16	0.3	0.6	24000	1.2x10 <sup>-6</sup>
SCGS-20	0.5	1.0	19000	3.5x10 <sup>-6</sup>
SCGS-25	1.0	2.0	15000	1.0x10 <sup>-5</sup>
SCGS-32	2.0	4.0	12000	3.1x10 <sup>-5</sup>